

· M · E · Z · Z · O ·



M O R D A U N T - S H O R T

Mezzo



Mezzo is an entirely new family of loudspeakers which offer staggering performance and earth-shattering design at incredible price points.

Mezzo – An object lesson in acoustic science

In 2004, something of a revolution took place at Mordaunt-Short. The legendary loudspeaker manufacturer produced the flagship Performance model which re-wrote the rule book and used some truly groundbreaking technologies never before seen in the hi-fi world. Performance has since won countless awards around the globe and is considered to be a modern classic.

Many of Performance's most significant features have now trickled down to the company's new range – Mezzo. All this means that true hi-fi bliss is available to a wider audience.

Consisting of a full loudspeaker series and a blend of scintillating sound and truly graceful aesthetics, Mezzo affords you the opportunity to experience music and movies truly as those involved intended, and what can be better than that?



40 years of Mordaunt-Short

2007 saw the 40th anniversary of Mordaunt-Short. Norman Mordaunt and Rodney Short went into partnership in 1967 to produce the world's first loudspeaker range. Models such as the Festival, Pageant and Carnival were received to rave reviews, something that has continued with all the company's current ranges including Mezzo. Mordaunt-Short has been responsible for developing truly innovative and legendary technologies such as Continuous Profile Cone (CPC), V-Form and Aspirated Tweeter Technology (ATT).

Throughout this period, the company has built up the reputation as one of the world's most respected loudspeaker manufacturers and one thing has been a constant over the last four decades – Mordaunt-Short's absolute dedication to producing affordable high quality hi-fi for all.



Core technology



Set-up and control the Mezzo 9 subwoofer from the comfort of your sofa with the easy to use SPL meter/remote control



Unique British design

All key technologies are designed at Mordaunt-Short's research and development headquarters in London, England. This means that each tweeter, drive unit and cabinet is created for a specific purpose – to integrate seamlessly to produce an astonishing sound for your music and video collection. Mordaunt-Short is proud of its attention to detail and desire to use the very best material throughout its ranges while delivering value for money. To this end, the finish on each cabinet is selected to mirror the designs of the finest contemporary furniture.



CPC aluminium cone technology

Continuous Profile Cone (CPC) technology produces predictable driver performance by ensuring controlled piston-like movement at low frequencies and minimal break up at higher frequencies. Lightweight yet rigid anodised aluminium cones are used for faithful dynamics. This advanced technology ensures stunningly realistic sound.

Digital Sound Processing (DSP)

The Mezzo 9 subwoofer features a powerful DSP engine which can be tailored to your exact set-up and room acoustics.

Notch filters allow response anomalies (room modes) to be equalised out and a Phase Compensation Filter (PCF) enables accurate step-by-step phase adjustment at the crossover point rather than the usual basic phase inversion switch on lesser products. The crossover point is fully adjustable and the roll-off rate selectable. A special test CD and combined Sound Pressure Level (SPL) meter/remote control are supplied making set-up surprisingly simple.

In use the DSP's engine is able to implement 'Night' modes and other dynamic processing so that for instance low level sounds are made louder whilst

at the same time explosions appear quieter, ideal for late-night listening. All these features can be easily controlled from the intuitive display panel and this kind of technology once again puts Mordaunt-Short at the forefront of home cinema entertainment.

V-Form technology

An innovative driver cone connection that creates a bigger, purer soundstage and helps maintain assembly rigidity. The surround thickness varies, aiding accurate piston-like operation and allowing the dish to operate freely, delivering benefits in timing performance.

Mordaunt-Short's flagship Performance challenged the status quo when it was launched and embraced some truly remarkable design innovations, many of which have disseminated down into Mezzo.

Technology



ATT Aspirated Tweeter

Aspirated Tweeter Technology (ATT)

Mezzo uses patent pending proprietary Aspirated Tweeter Technology (ATT) – a truly groundbreaking design that was first seen in the now legendary Performance series. Using state-of-the-art injection moulding, the elongated unit whose form is defined by complex acoustic principles – floats freely in a discrete enclosure. Along its length are strategically positioned vents eliminating the colouration which plagues traditional closed-back designs. This unusual venting system means Mezzo's high frequency drivers literally 'breathe', resulting in an open yet detailed sound.

Mordaunt-Short uses an advanced aluminium dome tweeter which the company has been perfecting for over 20 years. The ultra thin diaphragm and compression moulded surround is mounted on a low resonance chassis. The tweeter utilises a high temperature voice coil with liquid cooling and damping to ensure controlled high frequency performance with excellent detail.

Sound deadened driver baskets and curved cabinet design

The drive units are mounted on a unique, critically profiled sound deadened driver basket chassis with elastomer damping which completely eliminates unwanted resonance effects.

Most loudspeaker cabinets are cuboid which generate standing waves that affect performance. Mezzo speakers employ a curved cabinet design which minimises unwanted internal reflections produced by parallel planes. The cabinets themselves are carefully folded and pressed to form an extremely dense environment in which to house the drive units which again reduces distortion and resonance. Each panel is made up of differing thickness to aid dispersion and reflection of standing waves. The curves also offer



Sound deadened driver basket

an aesthetic boon as they give the appearance of a far smaller cabinet but in actual fact provide a bigger enclosure for a more commanding sound. Critical bracing is then used to strengthen key areas of the cabinet to ensure a superb sound.

Crossover

The components used in the crossover were critically selected for their signal path integrity including high quality polypropylene capacitors in Dual Value Parallel (DVP) configuration which produce outstanding treble. Coiled inductors with low current saturation characteristics greatly reduce non-linear distortion artefacts for an extremely clean and detailed sound. The crossover itself is isolate mounted further reducing vibration and unwanted resonance.

Two-channel



Enjoy two-channel stereo bliss with the Mezzo 2 standmount and Mezzo 6 and 8 floorstanders.

Two-channel



Mezzo 2 standmount speaker

Belying its compact size, Mezzo 2 embraces ATT to produce a remarkably expansive sound and stereo image and is the ideal two-channel stereo speaker. After a lengthy research process, Mordaunt-Short has rewritten the rule book and taken its legendary CPC™ (Continuous Profile Cone) bass drivers to the next level. These combine with a sound deadened driver basket for a superb all round listening experience. The cabinet's curved shape discourages the build up of standing waves for a cleaner and more realistic sound. Indeed it is unusual to get this level of performance from such a small speaker. Relax, sit back, close your eyes and you'll think you're sitting before your favourite orchestra or rock group.



Mezzo 6 floorstander

For the richest, most dramatic soundstage, the Mezzo 6 floorstander is unbeatable. Using twin 6½" CPC mid/bass drivers but with the added bass extension that only an elongated cabinet can produce, this 2½ way speaker produces a commanding performance. A hand-picked wood composite is laminated and pressed for consistent reproduction of every frequency. Once again, the incredible ATT tweeter takes care of the high notes delivering highly detailed yet controlled treble to your ears. Let Mezzo 6 release your music collection.



Mezzo 8 floorstander

For those wanting an even more commanding sound with substantial and sustained bass, look no further than the Mezzo 8 floorstander. Using all the technology present in the rest of the range including the ATT tweeter, Mezzo 8 is a true 3-way design - the 5.25" mid range has its own enclosure and is completely separate from the two 6.5" bass drivers ensuring it deals solely with its allotted bandwidth. This produces a phenomenally detailed and focussed sound stage.

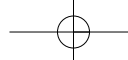

Multi-channel



Mezzo's home cinema set-up will put you at the heart of the action and let you experience every cinematic nuance. The Mezzo 1 and 5 produce a consistent and dynamic sound stage while the Mezzo 9 subwoofer provides low-end frequencies for maximum impact with the latest movies.

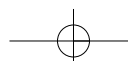
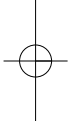
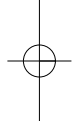

With Mordaunt-Short's new Mezzo system you'll be selling popcorn at the front door as your friends flock to enjoy your home cinema experience.

Multi-channel



Mezzo 1 rear effects/bookshelf

The Mezzo 1 proves that Mordaunt-Short's trademark sound can be delivered from the smallest of cabinets and offers a taste of genuine high-end hi-fi at a more than attainable price. The ATT tweeter is featured in its most compact cabinet to date and coupled with a 5¼" driver, this petite bookshelf speaker offers a deep and rich performance as well as an impressively large sound stage. Mezzo 1 was designed with two specific purposes in mind; to act as a satellite or rear effect speaker in a home theatre system or as a sublime stereo bookshelf speaker for smaller environments with audiophile reproduction requirements. Either way, these beautiful speakers fit perfectly anywhere.



Mezzo 5 centre

The Mezzo 5 is a dedicated centre in woofer-tweeter-woofer configuration designed to deal with the demands of dialogue in movies. Its ATT tweeter integrates fantastically with the rest of the range to produce awesome vocals. The cabinet is a closed box design while the infinite front baffle guarantees consistent dispersion characteristics and performance. In short, your movie collection will burst into your living room!



Mezzo 9 subwoofer

The Mezzo 9 is the result of an exhaustive research and development process with one aim – to produce the ultimate sub at an affordable price. The results are truly mind-blowing. Using dual opposed 8" CPC ultra long throw woofers in a force cancelling configuration for ultra stability and minimal vibration, the sub meters out a thumping 375 Watts of power. All this comes from an incredibly compact cabinet which integrates perfectly into any listening environment.

The Mezzo 9 is designed to be used in any combination from 2.1 right through to 7.2 set-ups and uses a Class D digital amplifier for efficient cool running.

It is also extremely user friendly and lets you take control via an ergonomic Sound Pressure Level (SPL) meter and remote control in one handset. Music/Movie/Game modes allow the sub to be tailored for specific uses which can be quickly switched between thanks to presets.

Your Mordaunt-Short dealer will be able to offer more information when you visit them for a hands-on demonstration.

Core technology

What's inside

1. ATT tweeter with 25mm aluminium dome for the most revealing high frequencies
2. Easily removable magnetic grilles sit flush against the baffle for the perfect fit
3. Rubber isolate mounted tweeter which enables it to float free from the cabinet
4. Internal wadding for critical damping of standing waves
5. Internally partitioned for a 2½ way design which means one driver deals solely with low end frequencies
6. Sound deadened driver baskets which completely eliminate unwanted resonance effects
7. Cabinet and driver bracing for ultimate rigidity and support
8. Simple crossover design for cleaner signal path. Isolate mounted to reduce distortion
9. Custom designed biwireable bullet terminals for optimal connection
10. Curved cabinet design to reduce standing waves
11. Custom designed feet for hard/wood flooring and spikes for carpeted interiors
12. X-Squared curved port flare termination for smooth air dispersion
13. Twin latest generation 6½" CPC drivers for a commanding and expansive sound stage

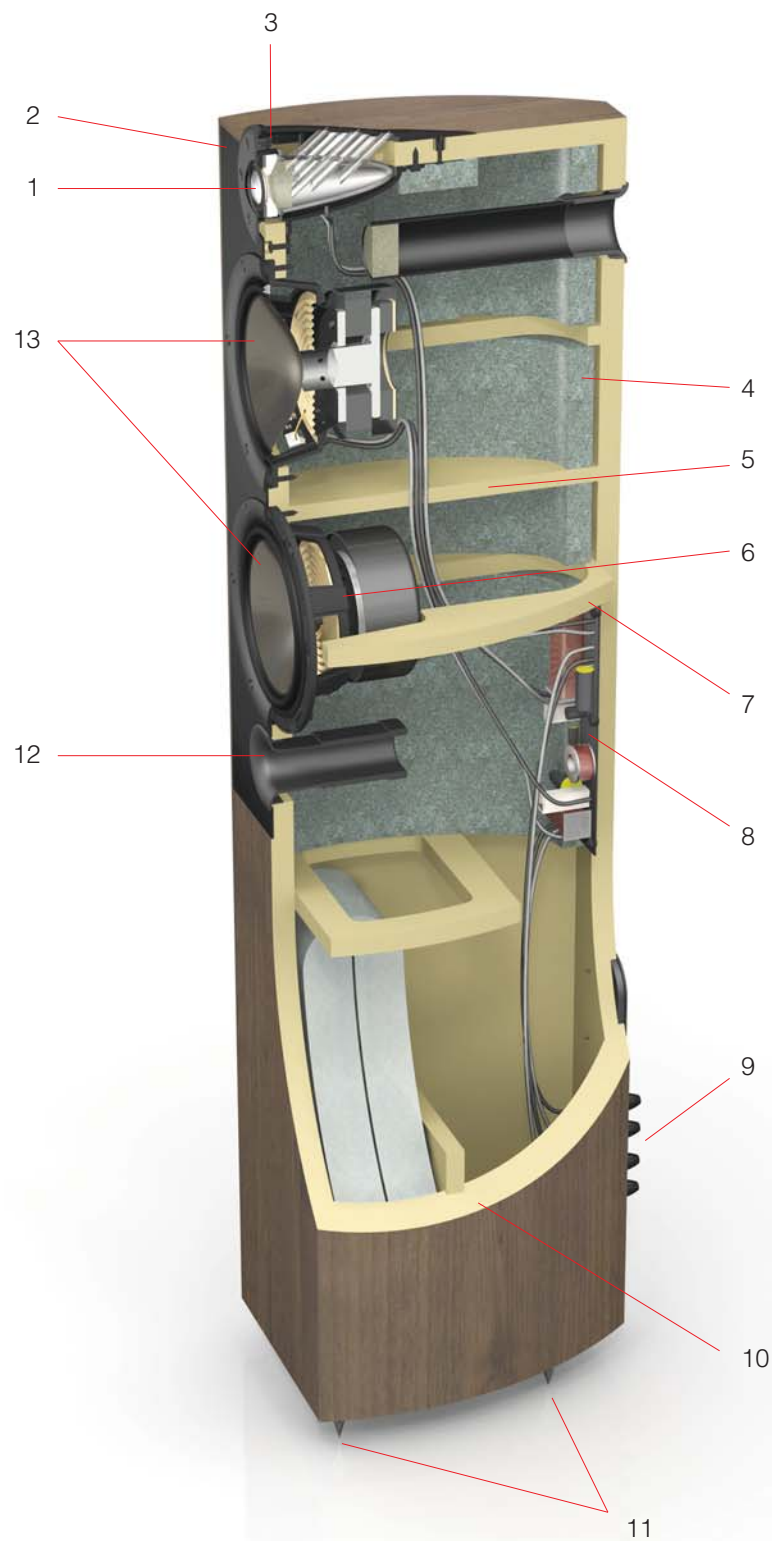

The Mezzo range is designed to exacting standards to produce the ultimate performance with both music and movies.

Specifications



Mezzo 1

| | |
|---------------------------------|---|
| Sensitivity | 88dB |
| Frequency response | 55Hz – 22kHz |
| Impedance | 4-8 Ohms |
| Drive units | (1) 133mm/5.25" aluminium CPC mid/bass driver (1) 25mm/1" ATT aluminium dome tweeter |
| Crossover | 2nd order with DVP |
| Recommended amplifier power | 15 – 100 Watts |
| Magnetic shielding | Yes |
| Dimensions (mm/inches) (hxwx d) | 300 x 204 x 255mm 11.8 x 8.0 x 10.0" |
| Weight | 6.2kg (13.7lbs) |

Mezzo 2

| | |
|---------------------------------|--|
| Sensitivity | 89dB |
| Frequency response | 48Hz – 22kHz |
| Impedance | 4-8 Ohms |
| Drive units | (1) 165mm/6.5" aluminium CPC mid/bass driver (1) 25mm/1" ATT aluminium dome tweeter |
| Crossover | 2nd order with DVP |
| Recommended amplifier power | 15 – 120 Watts |
| Magnetic shielding | Yes |
| Dimensions (mm/inches) (hxwx d) | 352 x 220 x 280mm 13.9 x 8.7 x 11.0" |
| Weight | 8.0kg (17.6lbs) |

Mezzo 5

| | |
|---------------------------------|--|
| Sensitivity | 89dB |
| Frequency response | 60Hz – 22kHz |
| Impedance | 4-8 Ohms |
| Drive units | (2) 133mm/5.25" aluminium CPC mid/bass drivers (1) 25mm/1" ATT aluminium dome tweeter |
| Crossover | 2nd order with DVP |
| Recommended amplifier power | 15 – 120 Watts |
| Magnetic shielding | Yes |
| Dimensions (mm/inches) (hxwx d) | 175 x 491 x 251mm 6.9 x 19.3 x 8.5" |
| Weight | 8.8kg (19.4lbs) |

Mezzo 6

| | |
|---------------------------------|---|
| Sensitivity | 89dB |
| Frequency response | 38Hz – 22kHz |
| Impedance | 4-8 Ohms |
| Drive units | (2) 165mm/6.5" aluminium CPC mid/bass drivers (1) 25mm/1" ATT aluminium dome tweeter |
| Crossover | 2nd order with DVP |
| Recommended amplifier power | 15 – 150 Watts |
| Magnetic shielding | Yes |
| Dimensions (mm/inches) (hxwx d) | 1000 x 220 x 280mm 39.4 x 8.7 x 11.0" |
| Weight | 20kg (44lbs) |

Mezzo 8

| | |
|---------------------------------|--|
| Sensitivity | 89dB |
| Frequency response | 35Hz - 22kHz |
| Nominal Impedance | 4-8 ohms |
| Drive units | (2) 165mm/6.5" aluminium CPC bass driver (1) 133mm/5.25" aluminium CPC mid-driver (1) 25mm/1" ATT aluminium dome tweeter |
| Crossover | 2nd order with DVP |
| Amplifier power | 15-200 watts |
| Magnetic shielding | Yes |
| Dimensions (mm/inches) (hxwx d) | 1072 x 220 x 307mm 42.9 x 8.7 x 12.3" |
| Weight | 23.8kg (52.4lbs) |

Mezzo 9

| | |
|---------------------------------|---|
| Sensitivity | Max input 2V RMS |
| Frequency response | 30Hz – 200Hz |
| Impedance | Input impedance: 10k Ohms |
| Drive units | (2) 203mm/8" aluminium CPC long throw woofers |
| Crossover | Active/variable |
| Amplifier power | 375W Active / Max power consumption: 600W |
| Magnetic shielding | Yes |
| Dimensions (mm/inches) (hxwx d) | 315 x 338 x 350mm 12.4 x 13.3 x 13.8" |
| Weight | 21.1kg (46.4lbs) |

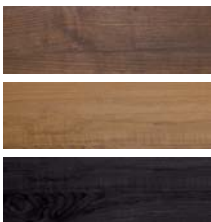

Dark walnut
Light oak
Black

Finishes

Whatever your listening environment, our striking light oak, black and dark walnut finishes will make your Mezzo speakers feel right at home while easily removable magnetic grilles sit flush against the front baffle and snugly around the tweeter.

Mordaunt-Short's policy is one of continuous improvement. Design and specifications are therefore subject to change without prior notice.

For the very latest, in-depth product information, review coverage, and extensive product support, visit www.mordaunt-short.com



© 2008 Mordaunt-Short
Mordaunt-Short Limited
Registered Office:
Gallery Court, Pilgrimage Street, London
SE1 4LL, United Kingdom
Registered in England No. 3823812
www.mordaunt-short.com

Your Mordaunt-Short specialist

AP25145/1